

YOUR NAME: Part III Solution

	1	2	3	4	5	6	7	8	9	10
A										
B										
C										
D										
E										

For questions 1-10: Mark your answers in the table above.

- 1) A 4kg object is moving with a speed of 3m/s. What is its momentum?
 A) 18 kg m/s B) 12 kg m/s C) 9 kg m/s D) 6 kg m/s E) 4 kg m/s
 $4\text{kg} \times 3\text{m/s} = 12 \text{ kg m/s}$
- 2) A 4kg object initially moving at a speed of 3m/s eastward collides with a 3kg object moving westward at a speed of 4m/s. After the collision, they stick together. What is their final speed?
 A) 3.5 m/s B) 7 m/s C) 0 m/s D) 12 m/s E) 24 m/s
 $(4\text{kg} \times 3\text{m/s}) - (3\text{kg} \times 4\text{m/s}) = 7\text{kg} \times 0\text{m/s}$
- 3) What happens to the total kinetic energy at the collision of question 2)?
 A) It remains the same.
 B) The 4kg object's kinetic energy gets transferred to the 3kg object.
 C) It gets doubled.
 D) It decreases.
 E) Initially it is zero, but the collision produces a positive kinetic energy.
 $K_i = \frac{1}{2} \times 4\text{kg} \times (3\text{m/s})^2 + \frac{1}{2} \times 3\text{kg} \times (-4\text{m/s})^2 = 42\text{J}$
 $K_f = 0$
- 4) Convert 3500 revolutions per minute to radians per second.
 A) 0.96 rad/s B) 58 rad/s C) 21991 rad/s D) 6.1 rad/s E) 367 rad/s
 $3500 \text{ rev/min} \times (2\pi \text{ rad/rev}) \times (\text{min}/ 60\text{s}) = 367 \text{ rad/s}$
- 5) A circular disk is spinning with an initial angular velocity of 4 rad/s and a constant angular acceleration of 3 rad/s². What is its final angular velocity 5 seconds later?
 A) 19 rad/s B) 7 rad/s C) 12 rad/s D) 60 rad/s E) 41.5 rad/s
 $\omega = 4 \text{ rad/s} + (3 \text{ rad/s}^2) \times (5 \text{ s}) = 19 \text{ rad/s}$

- 6) Five forces, A to E, of the same magnitude, are exerted on a circular disk as shown below. The disk cannot move but is free to rotate around its center axis. Which produces the greatest torque?

A) A B) B **C) C** D) D E) E

$$\tau = r F \sin\theta$$

Force C has $r=2m$ and $\theta=90^\circ$. Other forces have $r=0$ or $\theta < 90^\circ$.

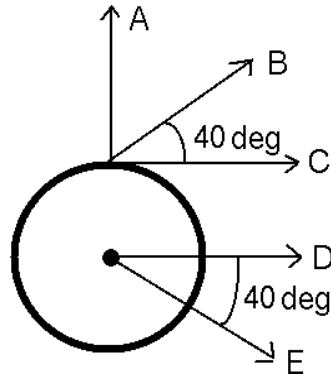

- 7) The disk has a radius of 2m, and the forces are 10N each in the above figure. How much torque is produced by force B?

A) 20 Nm B) 12.9 Nm C) 26.1 Nm **D) 15.3 Nm** E) 0 Nm

$$(2m) (10N) \sin(50^\circ) = 15.3Nm$$

- 8) How much torque is produced by force E?

A) 20 Nm B) 12.9 Nm C) 26.1 Nm D) 15.3 Nm **E) 0 Nm**

$$r = 0, \tau = 0$$

- 9) A circular disk, a solid sphere, and a ring of the same radius and same mass are rolling down an inclined surface without slipping. Which one reaches the bottom first? (HINT: They roll down from the same height. Which one has the largest velocity at the bottom?)

A) disk **B) sphere** C) ring D) disk and sphere E) all at the same time

$$Mgh = \frac{1}{2} MV^2 + \frac{1}{2} I (V/R)^2 = \frac{1}{2} (M + I/R^2)V^2$$

Sphere has the smallest moment of inertia and thus the largest V.

- 10) An ice skater with his arms stretched out has a moment of inertia of 2.4 kgm² and spins with an angular speed of 20 rad/s initially. When he folds his arms in, his moment of inertia changes to 1.2 kgm². What is his final angular speed?

A) 10 rad/s **B) 40 rad/s** C) 20 rad/s D) 28.3 rad/s E) 14.1 rad/s

$$I_i \omega_i = I_f \omega_f$$

$$\omega_f = 20 \text{ rad/s} \times 2.4 \text{ kgm}^2 / 1.2 \text{ kgm}^2 = 40 \text{ rad/s}$$

(Note: corrections in blue)

YOUR NAME: _____ **Part III Solution** _____

11) Two objects of mass 3kg are attached to massless strings of length 5.1m as shown below. Initially, when object A is released gently from its horizontal position, object B is hanging vertically without motion. The two objects stick together after collision. Calculate the maximum height (h) reached by the combined objects. Show all your work on this page and enter your final answer here. **ANSWER: 1.275 m (1.3m is okay)**

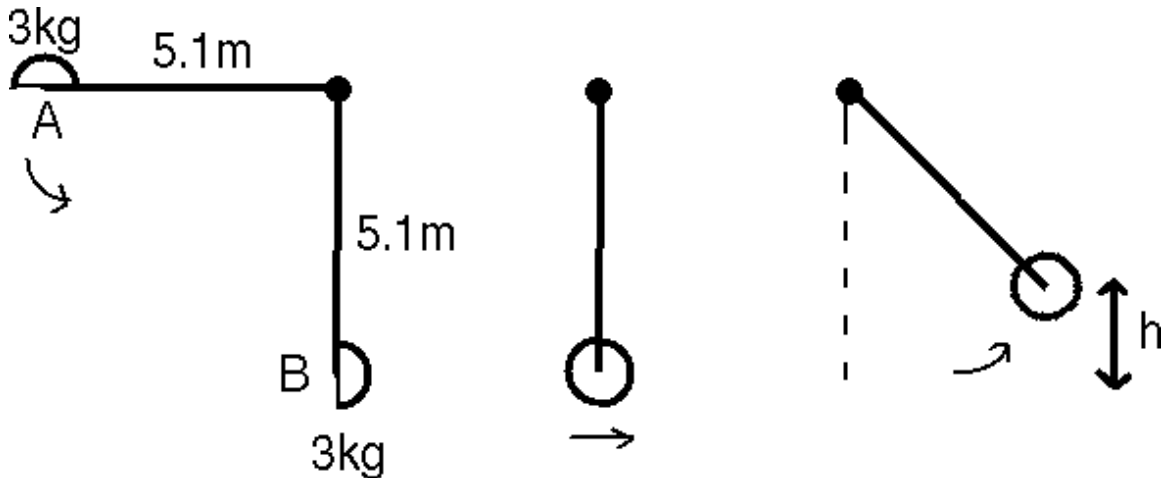

$$M = 3 \text{ kg}$$

$$D = 5.1 \text{ m}$$

$$V_A = \text{speed of A before collision}$$

$$V_{AB} = \text{speed of A+B after collision}$$

Step 1: Mechanical energy conservation before collision : $M g D = \frac{1}{2} M V_A^2$

$$V_A^2 = 2gD$$

Step 2: Momentum conservation during collision: $M V_A + 0 = (2M) V_{AB}$

$$V_{AB} = \frac{1}{2} V_A$$

Step 3: Mechanical energy conservation after collision: $\frac{1}{2} (2M) V_{AB}^2 = (2M) g h$

$$h = \frac{1}{2} V_{AB}^2 / g = \frac{1}{2} (\frac{1}{2} V_A)^2 / g = \frac{1}{4} (gD) / g = \frac{1}{4} D = \frac{1}{4} (5.1\text{m}) = 1.275 \text{ m}$$

(Note: You can also do this problem using angular momentum conservation in Step 2.)