

Unit 3: Name: _____

1. Four smiley faces are situated along the x axis as follows: $m_1 = 5$ kg at -5.0 m, $m_2 = 3$ kg at -2.0 m, $m_3 = 3$ kg at 1.0 m, and $m_4 = 2$ kg at 3.0 m. Where is the center of mass situated?

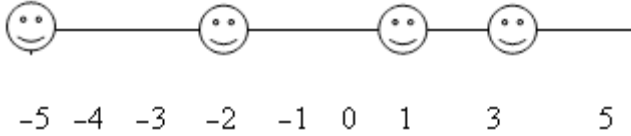

- A) 3.1 m B) 0.0 m C) -1.7 m D) -0.80 m E) -3.1 m
2. Two masses M and $5M$ rest on a horizontal frictionless table with a compressed spring of negligible mass between them. When the spring is released, the energy of the spring is shared between the two masses in such a way that
- A) M gets $3/5$ of the total energy. D) M gets $4/5$ of the total energy.
B) M gets $1/6$ of the total energy. E) None of these will occur.
C) M gets $1/5$ of the total energy.
3. Two cars of equal mass travel in opposite directions at equal speeds. They collide in a perfectly inelastic collision. Just after the collision, their velocities are
- A) zero.
B) equal to their original velocities.
C) equal in magnitude but opposite in direction to their original velocities.
D) less in magnitude and in the same direction as their original velocities.
E) less in magnitude and opposite in direction to their original velocities.
4. An 1810-kg truck traveling eastward at 64.4 km/h collides at an intersection with a 905-kg automobile traveling northward at 96.5 km/h. The vehicles lock together and immediately after the collision are headed in which direction?
- A) 30° N of E B) 37° N of E C) 45° N of E D) 53° N of E E) 67° N of E
5. A turntable rotating at 8.0 rad/s slows to a stop in 10 s. If the acceleration is constant, the angle through which the turntable rotates in the 10 s is
- A) 0.80 rad B) 0.40 rad C) 40 rad D) 80 rad E) 16 rad
6. A uniform disk ($I_o = \frac{1}{2} mR^2$) of mass m and radius R is suspended from a point on its rim. The moment of inertia of the disk about an axis perpendicular to the disk through the pivot point is
- A) $\frac{1}{2} mR^2$ B) mR^2 C) $1.5mR^2$ D) $2mR^2$ E) $2mR^2/3$
7. A disc is free to rotate about an axis. A force applied at a distance d from the axis causes an angular acceleration α . What angular acceleration is produced if the same force is applied a distance $2d$ from the axis?
- A) α B) 2α C) $\alpha/2$ D) 4α E) $\alpha/4$

8. A wheel is rotating clockwise on a fixed axis perpendicular to the page (x). A torque that causes the wheel to slow down is best represented by the vector

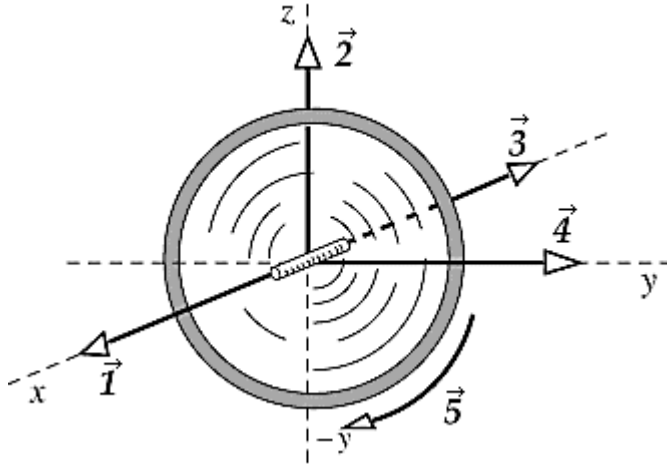

- A) $\vec{1}$ B) $\vec{2}$ C) $\vec{3}$ D) $\vec{4}$ E) $\vec{5}$

9. The vector \vec{C} represents

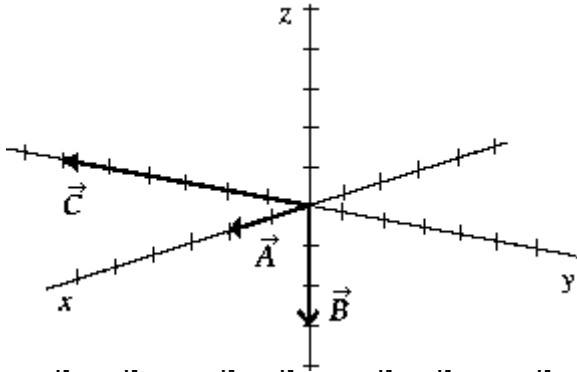

- A) $\vec{A} \times \vec{B}$ B) $\vec{B} \cdot \vec{A}$ C) $\vec{A} \cdot \vec{B}$ D) $\vec{B} \times \vec{A}$ E) None of these are correct.

10. The angular momentum of a rotating object is initially $\vec{L}_i = 2\hat{i} + 4\hat{j}$ and 2s later it is $\vec{L}_f = 3\hat{i} + 8\hat{j}$.

The units are in $\text{kg}\cdot\text{m}^2/\text{s}$. The torque that produces the change in angular momentum is

- A) $-0.5\text{N}\cdot\text{m}\hat{i} - 2\text{N}\cdot\text{m}\hat{j}$ D) $1\text{N}\cdot\text{m}\hat{i} + 4\text{N}\cdot\text{m}\hat{j}$
 B) $0.5\text{N}\cdot\text{m}\hat{i} + 2\text{N}\cdot\text{m}\hat{j}$ E) none of the above
 C) $-1\text{N}\cdot\text{m}\hat{i} - 4\text{N}\cdot\text{m}\hat{j}$

11. **(Show all work)** A block of wood with a mass $M = 4.65$ kg is resting on a horizontal surface when a bullet with a mass $m = 18$ g and moving with a speed $v = 725$ m/s strikes and lodges into it. The coefficient of friction between the block and the surface is $\mu = 0.350$.

(a) The speed of the block immediately after the collision is

(b) Immediately after the collision, the vertical force on the block/bullet due to the surface is

(c) The horizontal force on the block/bullet immediately after the collision (just after the block starts sliding across the surface) is

(d) The distance the block moves across the surface is

Answer Key

1. C $[5(-5) + 3(-2) + 3(1) + 2(3)] / (5 + 3 + 3 + 2) = -1.7 \text{ m}$
2. E $K_M / (K_M + K_{5M}) = p^2 / 2M / [p^2 / 2M + (-p)^2 / 2(5M)] = 1/2 / (1/2 + 1/10) = 5/6$
3. A zero
4. B $\tan\theta = p_N / p_E = (905\text{kg} \cdot 96.5\text{km/h}) / (1810\text{kg} \cdot 64.4\text{km/h}) = .749, \quad \theta = 36.8^\circ \text{ N of E}$
5. C $2 \cdot (8\text{rad/s} / 10\text{s}) \cdot \theta = (8\text{rad/s})^2 - 0^2 \quad \theta = 40 \text{ rad}$
6. C $\frac{1}{2} mR^2 + mR^2 = 1.5 mR^2$
7. B torque doubles implies α doubles
8. A \hat{i}
9. D $\vec{B} \times \vec{A}$
10. B $\Delta L / \Delta t = [(3-2)\hat{i} + (8-4)\hat{j}] / 2 = (.5\hat{i} + 2\hat{j}) \text{ N} \cdot \text{m}$

11. (a) $.018\text{kg} \cdot 725\text{m/s} = (4.65 + .018)\text{kg} \cdot V \quad V = 2.80\text{m/s}$
(b) $4.668\text{kg} \cdot 9.81\text{m/s}^2 = 45.8\text{N}$
(c) $.35 \cdot 45.8\text{N} = 16.0\text{N}$
(d) $16.0\text{N} \cdot \Delta x = \frac{1}{2} \cdot 4.668\text{kg} (2.80\text{m/s})^2 - 0 \quad \Delta x = 1.14\text{m}$